

CERAMIC LINED MILLS

WET & DRY SIZE REDUCTION

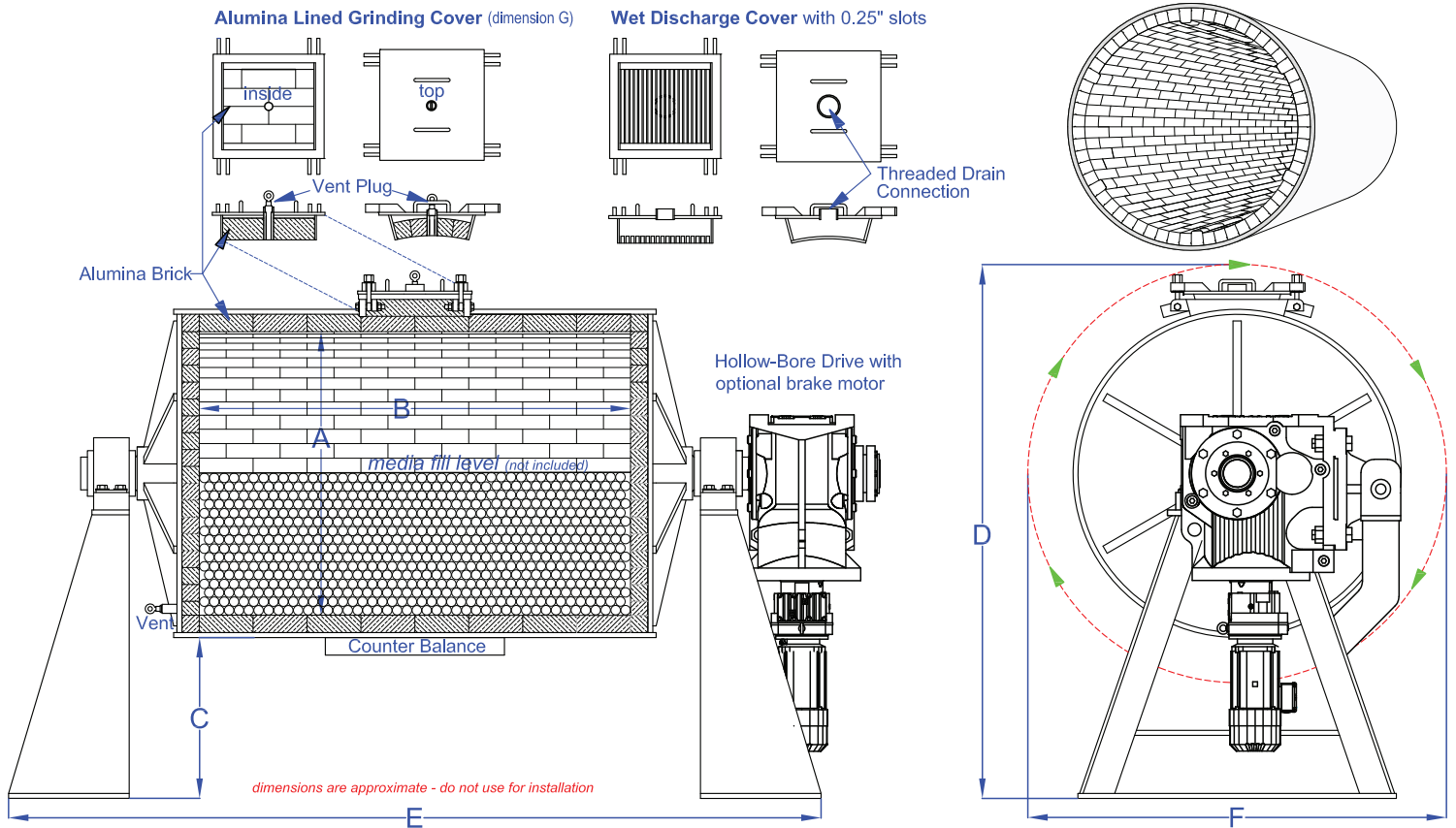

dimensions are approximate - do not use for installation

Model	Total Volume		WET Working Capacity (60% of total)		DRY Working Capacity (25% of total)		alumina media 50% charge pounds	rpm WET milling 60% of critical	rpm DRY milling 55% of critical	Cylinder and Overall Dimensions (inches)							weight (w/o media)
	usg	ft ³	usg	ft ³	usg	ft ³				A	B	C	D	E	F	G	
										cylinder diameter	cylinder length	cylinder to floor	height	length	depth	hatch	
CLM - 9	9	1.2	5.3	0.7	2.2	0.3	79	48	44	12	18	18	41	57	26	5.3 x 5.3	980
CLM - 16	16	2.1	10	1.3	4.0	0.5	144	43	39	15	21	18	44	60	32	7.75 x 9.25	1,200
CLM - 28	28	3.7	17	2.2	7	0.9	247	39	35	18	25	21	50	80	36	7.75 x 9.25	1,450
CLM - 40	40	5.4	24	3.2	10	1.4	363	36	33	21	27	21	53	85	39	7.75 x 9.25	2,050
CLM - 49	49	6.6	30	4.0	12	1.7	443	36	33	21	33	21	53	97	39	7.75 x 9.25	2,200
CLM - 60	60	8	36	4.8	15	2.0	538	30	28	29	21	23	64	88	46	7.75 x 9.25	2,550
CLM - 94	94	13	57	7.6	24	3.2	845	30	28	29	33	23	64	89	46	7.75 x 9.25	3,000
CLM - 163	163	22	98	13	41	5.4	1,459	28	26	33	44	23	69	116	51	13.25 x 14.75	4,750
CLM - 216	216	29	130	17	54	7	1,935	26	24	38	44	24	69	114	56	13.25 x 14.75	5,800
CLM - 251	251	34	151	20	63	8	2,253	25	23	41	44	24	75	125	58	13.25 x 14.75	6,800
CLM - 369	369	49	221	30	92	12	3,302	24	22	44	56	24	78	135	65	13.25 x 14.75	8,400
CLM - 374	374	50	224	30	94	13	3,350	23	21	50	44	24	81	123	78	13.25 x 14.75	8,500
CLM - 476	476	64	286	38	119	16	4,264	23	21	50	56	24	87	129	78	13.25 x 14.75	9,800
CLM - 469	469	63	282	38	117	16	4,202	21	20	56	44	26	87	142	77	13.25 x 14.75	12,500
CLM - 597	597	80	358	48	149	20	5,349	21	20	56	56	26	95	145	76	13.25 x 14.75	12,900
CLM - 725	725	97	435	58	181	24	6,495	21	20	56	68	26	95	171	75	13.25 x 14.75	13,100
CLM - 778	778	104	467	62	194	26	6,967	21	19	58	68	26	95	171	78	13.25 x 14.75	13,600
CLM - 880	880	118	528	71	220	29	7,886	19	18	68	56	36	97	162	89	13.25 x 14.75	19,900
CLM - 1069	1,069	143	641	86	267	36	9,576	19	18	68	68	36	117	177	89	13.25 x 14.75	21,200
CLM - 1446	1,446	193	868	116	362	48	12,956	19	18	68	92	36	117	210	89	13.25 x 14.75	25,100
CLM - 1635	1,635	219	981	131	409	55	14,646	19	18	68	104	36	117	225	89	13.25 x 14.75	26,200
CLM - 1824	1,824	244	1,094	146	456	61	16,336	19	18	68	116	36	117	232	89	13.25 x 14.75	28,400
CLM - 2850	2,850	381	1,710	229	712	95	25,525	17	16	85	116	42	140	252	110	13.25 x 18	32,600

Talk with the Experts

phone 630.350.3012
sales@pauloabbe.com

fax 630.238.7584
www.pauloabbe.com

CERAMIC LINED MILLS

WET & DRY SIZE REDUCTION

PAUL O. ABBE®
Since 1911

Dry Discharge requires the use of a dust tight enclosure.



Alumina Lined Grinding Cover (dimension G)

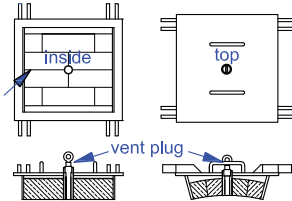

Wet Discharge Cover with 0.25" slots

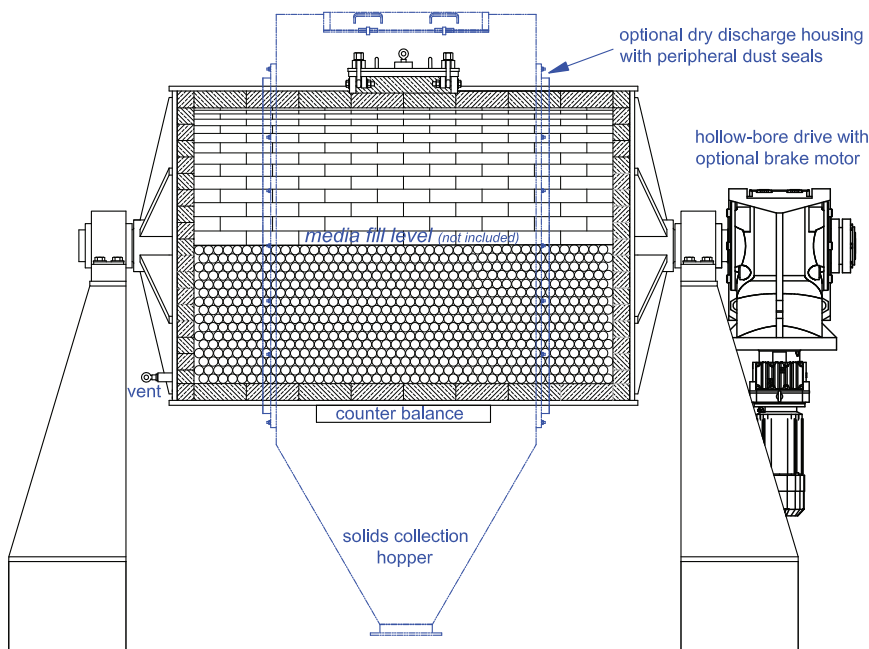
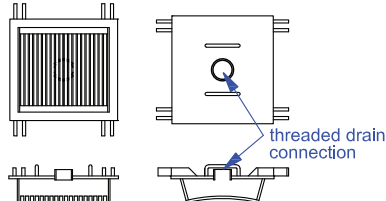

optional dry discharge housing with peripheral dust seals

hollow-bore drive with optional brake motor

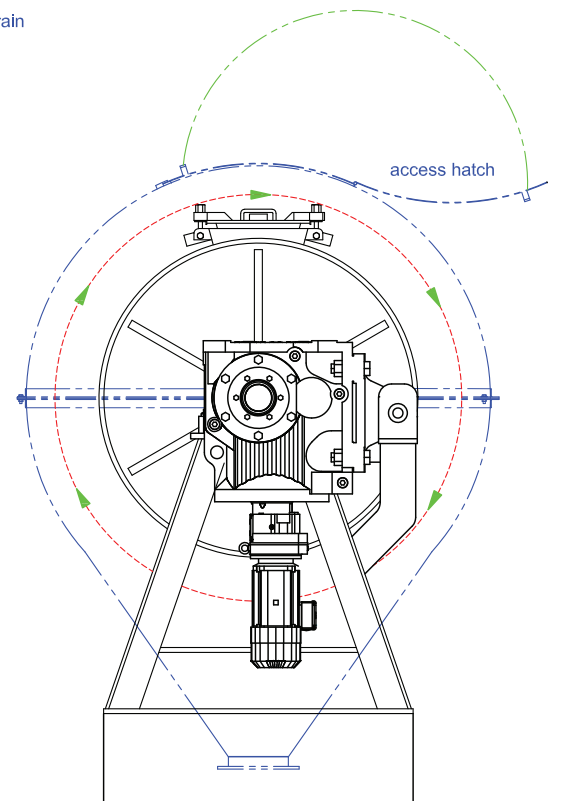

access hatch

Talk with the Experts

phone 630.350.3012
sales@pauloabbe.com

fax 630.238.7584
www.pauloabbe.com